

Vehicle Inspectors Bulletin



50

Issued
May 2003

Installation of aftermarket seat belts in ME category (large) buses and coaches

Background

Increased demand for improved occupant protection in buses and coaches has led to many buses and coaches not originally fitted with seat belts being retro-fitted with seat belts.

Retro-fitted seat belts are required to be installed in accordance with one of the standards listed below and to be certified by a recognised engineering signatory.

- Voluntary Modification of Existing Buses & Coaches - Guidelines to Improve Occupant Protection.
- Vehicle Standards Bulletin No 6 (VSB6) - Heavy Vehicle Modifications (Vehicles over 4.5 tonnes GVM).
- The Australian Design Rules (ADRs).

I. Acceptable seat belt installations

Improved bus occupant protection has been introduced in two stages. First was the introduction of ADR 66 Seat Strength, Seat Anchorage Strength and Padding in Omnibuses. (10g static or dynamic test) followed by ADR 68 Occupant Protection in Buses (20g dynamic test). VSB6 reflects the more stringent 20g requirement, as opposed to the voluntary guidelines, which reflect the minimum acceptable requirement of 10g. The RTA considers that buses retro-fitted with seat belts capable of withstanding a 10g deceleration are acceptable. Essentially these installations need to satisfy each of the following requirements:

- The minimum bolt spacing for seat mountings is no less than 300mm.
- The wall mountings have been modified.
- The floor mountings have been reinforced.

For: • RTA Inspectors Vehicle Regulation • Engineering Signatories
• RTA Registry Service Managers • HVAIS Proprietors & Examiners

1.1 Installations must have a minimum bolt spacing of 300mm on the seat mounting

These installations are generally considered acceptable, however an engineer's certificate must certify the fitting of the seat belts. Figure 1 illustrates an acceptable method of mounting a seat retro-fitted with seat belts.

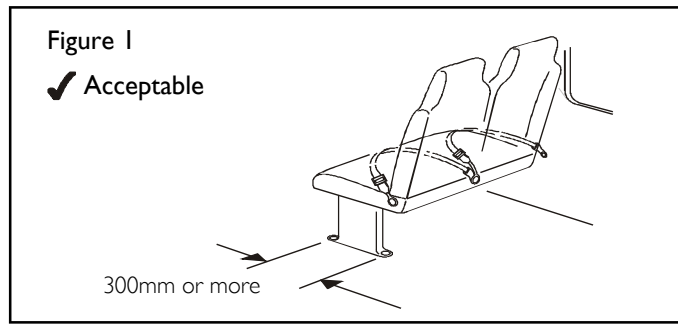

1.2 Installations must have the wall mounting modified with additional reinforcement

The Voluntary Guidelines identify different wall mounting constructions for seats in common vehicle models. Installations which are generally considered acceptable are modified in accordance with the Voluntary Guidelines. These typically include additional reinforcements, which are welded in lengths of 50mm for each 150mm on both the upper and lower edges, as well as directly to body frame members. Figure 2 illustrates a reinforced wall mounting which has been welded.

Alternatively, wall mounts which use extruded aluminium C-channels may be reinforced using 6mm steel rivets at 150mm spacing. Figure 3 illustrates a reinforced wall mounting which has been riveted.

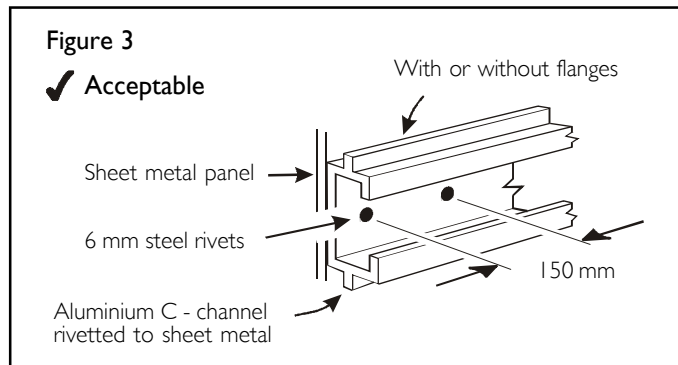
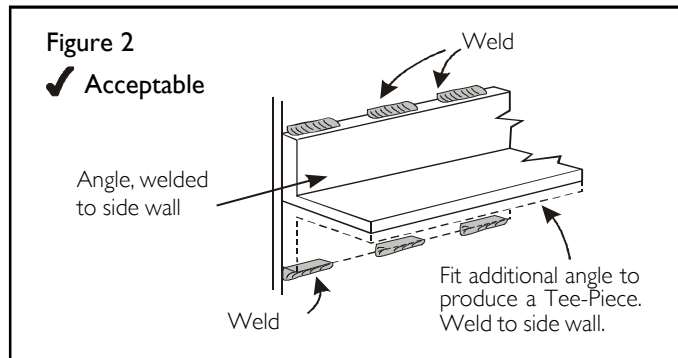

1.3 Installations must have floor mountings modified with additional reinforcement

The Voluntary Guidelines identify different floor mounting constructions in common vehicle models. Installations which are generally considered acceptable are modified in accordance with the Voluntary Guidelines. These typically include additional reinforcements which are welded to the bearer. Figure 4 illustrates a reinforced floor mounting.

The minimum bolt size for the seat mounting should be no less than 3/8" grade 5 or M10 grade 8.8. The anchorage should include the use of hardened washers and a nut as illustrated in Figure 5.

The bolt should be centrally located through the underfloor reinforcement and be long enough to fully engage the thread of the nut when tightened.

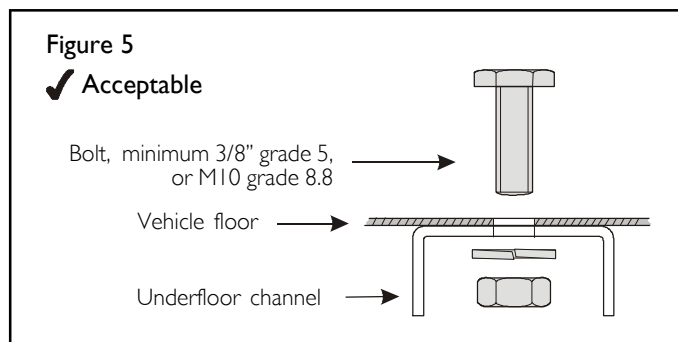
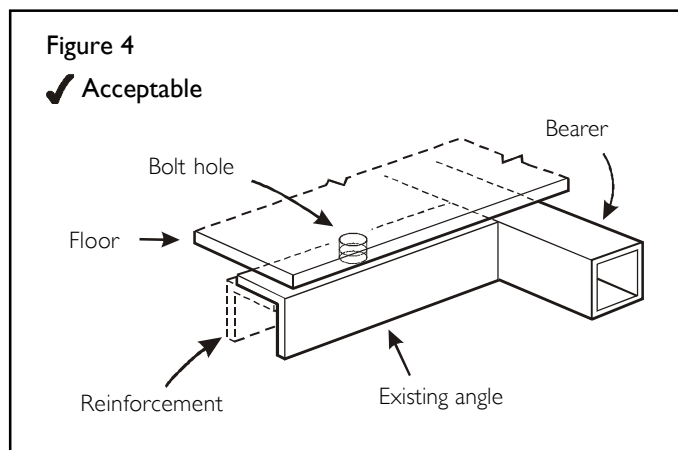

2. Unacceptable seat belt installations

The following seat belt installations are considered unacceptable:

- Installations which use bolts without hardened washers and nuts.
- Installations which incorporate cast aluminium legs.
- Installations where fitting may increase the likelihood of occupant injury.
- Installations which have less than 300mm bolt spacing.

2.1 Seat mountings and seat belt anchorages without a hardened washer and a nut

Seat belt installations which use bolts (as part of the seat or seat belt anchorage system) without a hardened washer and a nut are considered insufficient to withstand the loads transmitted through the seat or seat belt if the vehicle is involved in an accident. Figure 6 illustrates an unacceptable anchorage.

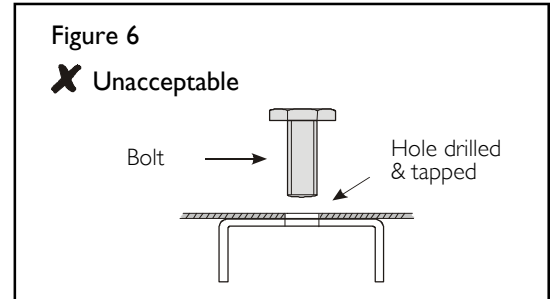

2.2 Seats which incorporate cast aluminium legs

Installations of seat belts to seats which use cast aluminium legs are considered unacceptable. Tests have shown failure of these types of seats. Such failures are particularly serious because portions of broken casting may remain projecting from the vehicle floor having the potential to cause injuries to occupants in crash situations.

2.3 Installations where fitting may increase likelihood of occupant injury

Occupant injury may occur when vehicles involved in accidents or severe braking conditions can cause passengers to be propelled forward and make contact with unyielding surfaces. As such, in addition to the certification of seat belts to the above standards, the installation of bars, rails and frames must be padded in accordance with Technical Specification 148 (which requires a high density padding between 200-300 kg/m³ with a minimum thickness of 25 mm). Figure 7 illustrates an installation which may increase likelihood of occupant injury.

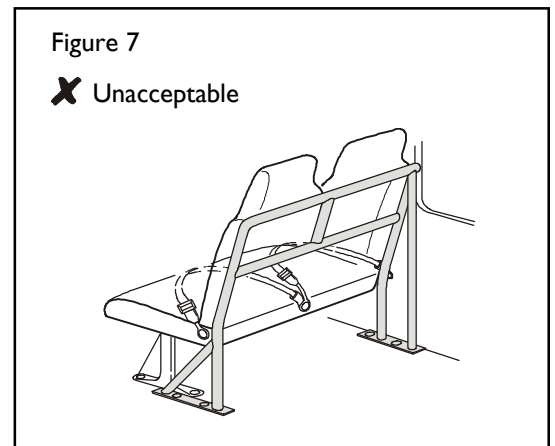

2.4 Installations which have seat anchorage bolt spacings less than 300mm

Installation of seat belts to seats which have leg mounting bolt spacing less than 300mm are unacceptable. Figure 8 illustrates an unacceptable seat mounting bolt spacing.

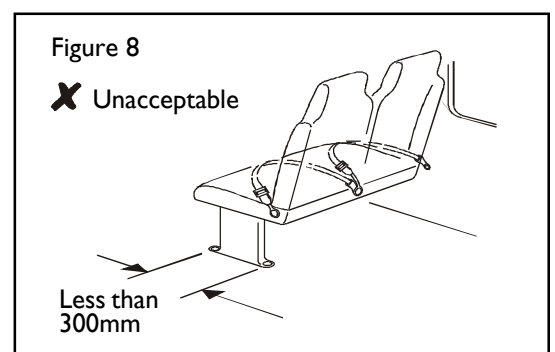

In cases where the seat belt installation falls into any of the unacceptable categories outlined in Section 2 above, the installation must be certified by a Recognised Engineering Signatory as having been dynamically tested and proven to meet the requirements of the 10g deceleration pulse outlined in ADR 66 Annex 4.

FULL COPIES OF TEST RESULTS MUST BE SUPPLIED IN ACCORDANCE WITH SECTION 3.

3. Action

When inspecting this type of vehicle pay particular attention to the items listed under "Reasons for rejection" below. If any unacceptable items are found the owner is to be advised that the vehicle is to be issued with a defect notice and the matter is to be referred to Heavy Vehicle Safety and Standards section for further assessment.

The details of any vehicle defected for any of these items (including a copy of the defect notice, photographs of the reason for rejection, the associated engineering certificate and a full copy of the test results) are to be forwarded to:

Manager, Heavy Vehicle Safety and Standards, Roads and Traffic Authority,
Level 7, 260 Elizabeth Street, Surry Hills, NSW 2010

4. Reasons for rejection

1. Seat mountings and seat belt anchorages which use bolts without hardened washers and a nut (figure 6).
2. Seats which incorporate cast aluminium legs.
3. Structures fitted to the vehicle (such as rails and frames without padding) which are likely to increase the risk of occupant injury (figure 7).
4. Seat belt installations which have bolt spacings less than 300mm on the seat leg mounting (figure 8).
5. Any bus with retro-fitted seat belts that is presented for inspection without an engineer's certificate for the seat belt installation.

Note: To help determine the mandatory seat belt requirements that the vehicle would have originally been fitted with, and which vehicles have been retro-fitted with seat belts, refer to the seat belt installation reference table below:

Seat belt installation reference table

Date of manufacture	Vehicle category	Number of seating positions	Seat belt requirements
From 1 July 1994	ME	Less than 17 seats	All seating positions, except in route buses & buses with a reference height less than 1 metre
		17 seats or more	Except for route buses, seat belts are required for non-protected seats

5. Enforcement

Defect	RTA Inspectors	HVIS Inspection (RTA Inspectors)	AIS, HVAIS & AUVIS (Authorised Examiners)
Seat belt installation does not meet the required standard	Defect Notice (up to 28 days to clear)	Defect Notice (up to 28 days to clear)	Issue a rejection certificate (white slip) in the normal manner
Structures fitted (frames & rails) present a safety risk	Defect Notice (up to 28 days to clear)	Defect Notice (up to 28 days to clear)	Issue a rejection certificate (white slip) in the normal manner



Further information:



Tel: 1300 137 302

Fax: (02) 9843 3821



www.rta.nsw.gov.au

Email: tech_enq@rta.nsw.gov.au



RTA Technical Enquiries

PO Box 1120 PARRAMATTA NSW 2124