

DETAIL A  
(NUTS AND WASHER REMOVED)  
1 : 2

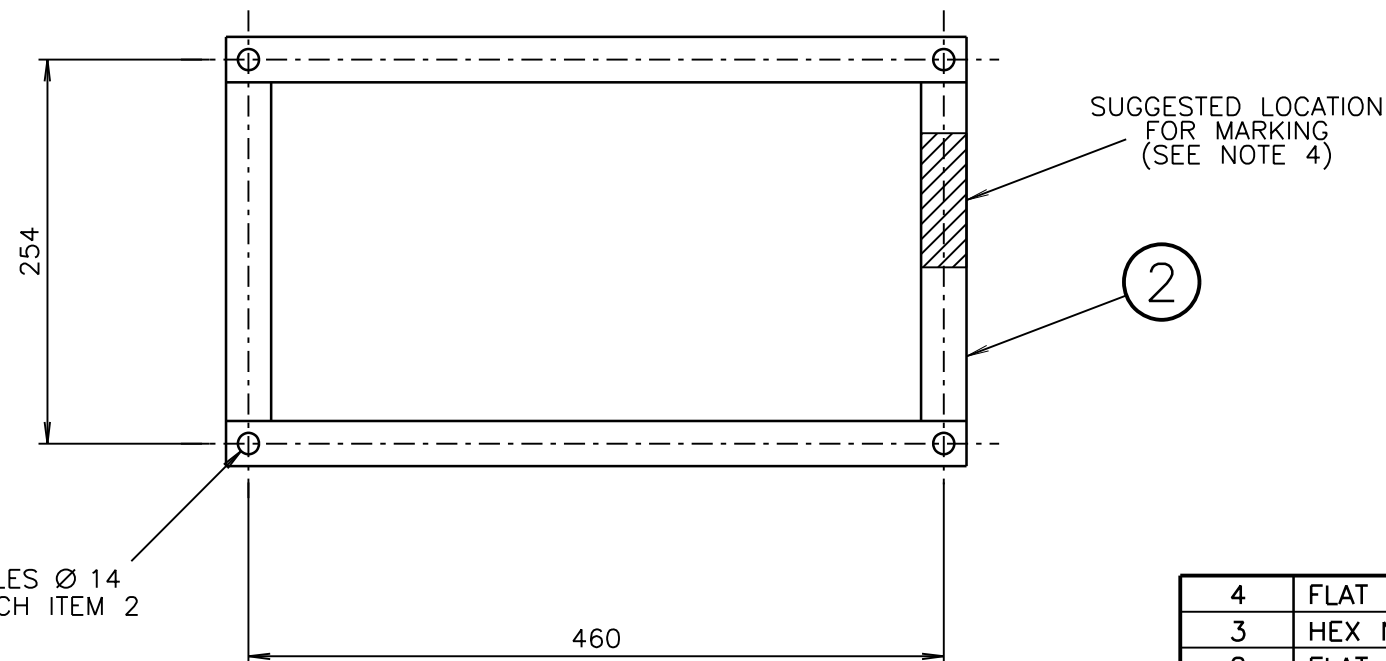

2 HOLES Ø 14  
IN EACH ITEM 2

NOTES

1. ALL WELDING SHALL BE IN ACCORDANCE WITH AS/NZS 1554 PART 1.
2. AFTER WELDING, ITEMS 1&2 TO BE HOT DIP GALVANISED IN ACCORDANCE WITH AS/NZS 4680 AND THREADED ENDS OF ITEM 1 IN ACCORDANCE WITH AS 1214.
3. ITEMS 3 AND 4 SHALL BE SUPPLIED AND FITTED (AS SHOWN) BY THE MANUFACTURER.
4. MANUFACTURER'S IDENTIFICATION AND DATE OF MANUFACTURE TO BE MARKED CLEARLY, LEGIBLY AND WATERPROOF.
5. THE GALVANISING SURFACE SHALL BE FREE FROM SHARP PROJECTIONS, DROSS AND DAGS.
6. TOLERANCE: ±2 UNLESS STATED OTHERWISE.

DIMENSIONS IN MILLIMETRES

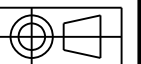

ITEM	DESCRIPTION	MATERIAL	FINISH	QTY
4	FLAT WASHER M12 NORMAL SERIES TO AS 1237	MILD STEEL	GAL TO AN/NZS 4680	4
3	HEX NUT M12 TO AS 1112	MILD STEEL	GAL TO AS/NZS 1214	8
2	FLAT BAR 30x6 TO AS 3679	MILD STEEL	GAL TO AN/NZS 4680	8
1	ROD Ø 12 STEEL ROUND TO AS 3679	MILD STEEL	GAL TO AN/NZS 4680	4

C ISSUE 28-04-98 JI TC2349 PLAN REDRAWN. ITEM 4 ADDED. WASHER ITEM 3 WAS NORMAL SERIES. RVC BWT	D ISSUE 29-01-10 PLAN REDRAWN. HOLDING-DOWN BOLT REVISED TO SUIT SOLID CONTROLLER FOOTING. REFERENCE TO THE PRECAST TOP DELETED. REFERENCE TO CCTV FOOTING ADDED. AC BWT	E ISSUE 30-03-10 ITEM 4 WAS LARGE SERIES. LC BWT	REFERENCE DRAWINGS		ROADS AND TRAFFIC AUTHORITY OF NSW TRAFFIC SIGNALS	SCALE 1 : 5		APPROVED: 17-11-1989 D VIEYRA MANAGER STDS & QUALITY		
			CONTROLLER FOOTING VC002-73	CCTV HSG FOOTING VC002-76		HOLDING-DOWN BOLT ASSEMBLY FOR GROUND-MOUNTED CONTROLLER AND CCTV HOUSINGS		SUPERSEDES: ISSUE B	DRAWN GC 06-02-87 CHECKED RB 26-02-87 PASSED B. TAYLOR 17-11-89	
RTA CATALOGUE NUMBER 18234159							VC002-56			